

NovAseptic® Valve Valve Body, Divert Valve

Catalogue Number NA##/39-211 and NU###/39-211

Valve Body, Divert Valve Configuration

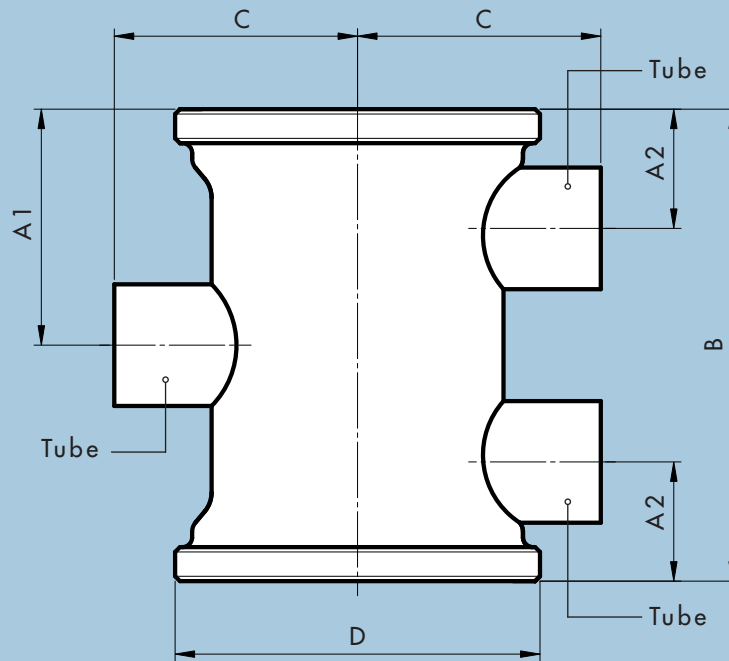

Nominal Dimensions in mm (in.)

A1	A2	B	C	D*	SMS Tube 3008		US Tube ASTM® A269/270		
					NA##	Tube	NU###	Size	Tube
25.0 (0.984)	13.7 (0.539)	50.0 (1.969)	30.0 (1.181)	TR40x2	NA12	12.0x1.0	NU050	½"	12.7x1.65 (0.50x0.065)
35.0 (1.378)	18.5 (0.728)	70.0 (2.756)	40.0 (1.575)	TR55x2	NA18	18.0x1.5	NU075	¾"	19.1x1.65 (0.75x0.065)
48.5 (1.909)	24.5 (0.965)	97.0 (3.819)	50.0 (1.969)	TR75x2	NA25	25.0x1.2	NU100	1"	25.4x1.65 (1.0x0.065)
68.3 (2.689)	31.2 (1.228)	136.5 (5.374)	60.0 (2.362)	TR85x2	NA38	38.0x1.2	NU150	1½"	38.1x1.65 (1.5x0.065)
87.7 (3.453)	37.7 (1.484)	175.5 (6.909)	75.0 (2.953)	TR109x2	NA51	51.0x1.2	NU200	2"	50.8x1.65 (2.0x0.065)

* Note: Non-standard thread, special thread to fit NovAseptic Actuators.

Specifications

Net Volume (valve cavity, diaphragm applied)

Valve Body	NA12/ NU050	NA18/ NU075	NA25/ NU100	NA38/ NU150	NA51/ NU200
Volume ml	7	20	60	160	480

Net Weight (approximate)

Valve Body	NA12/ NU050	NA18/ NU075	NA25/ NU100	NA38/ NU150	NA51/ NU200
Weight kg (lb)	0.2 (0.44)	0.5 (1.1)	1.3 (2.87)	2.4 (5.29)	4.8 (10.6)

Material

	Bar Stainless Steel in Compliance with		Tubing Stainless Steel in Compliance with	
Material Code	316L	EN 1.4404	TP316L	EN 1.4404
Technical Requirements	ASME® SA-479	EN 10272	ASTM® A269/270	EN 10217-7/ EN 10216-5

Specifications

Surface Roughness:	Internal surface (manually polished) $Ra \leq 0.5\mu\text{m}$ (20 μin) External surface $Ra \leq 1.6\mu\text{m}$ (63 μin)
Design Temperature, Valve Body:	-80 to 200 °C (-112 to 392 °F)
Design Pressure, Valve Body:	-1 to 10 bar(g) (-14.5 to 145 psi(g))
Note!	The applied diaphragm and actuator may have different design temperature and/or pressure limits. The weakest component in the assembled product determines the maximum design temperature and pressure limits.
Labeling:	Each Valve Body is individually labeled for full traceability and heat No. according to Millipore QA routines.
Packaging:	All open ends on the Valve Body are protected with plastic covers on delivery and packaged in a closed box.
Quality Control:	Millipore Quality Assurance System guarantees the control and traceability at all stages of the manufacturing.
In Compliance With:	The NovAseptic Valve is classified in Europe, under SEP (Sound Engineering Practice) for PED Directive 97/23/EC. NovAseptic Valve is in compliance with ASME® BPE standard. The NovAseptic Valve meets the requirements of the 3-A Sanitary Standards, marked on request.
Options:	For non-standard NovAseptic Valve Body Options, please contact Millipore for further information.

To Place an Order or Receive Technical Assistance

For additional information call your nearest Millipore office or visit us at www.millipore.com.
In the U.S. and Canada, call toll-free 1-800-MILLIPORE (1-800-645-5476). In the U.S., Canada and Puerto Rico, fax orders to 1-800-MILLIFX (1-800-645-5439).

MILLIPORE

Millipore and NovAseptic are registered trademarks of Millipore Corporation or an affiliated company.
ASME is a registered trademark of the American Society of Mechanical Engineers.
ASTM is a registered trademark of the American Society for Testing and Materials.
Specifications subject to change without notice.
Lit. No. SP1108EN00 Rev. -, 09/2006. Replaces DS-051
© 2006 Millipore Corporation. All rights reserved.